

Harnessing the power of millimeter wave radar for improving the orientation and mobility of the visually impaired

T.Kiuru and M. Metso

VTT Technical Research Centre of Finland Ltd.

During the previous decade or two, the miniaturization and rising operating frequencies have enabled integration of full millimeter wave radar front-end on a single silicon chip. These small, light-weight and low-cost systems have then opened door for the first mainstream application of millimeter wave technology: the automotive radar at 77 GHz, which is now in use in millions of high-end cars around the world. In addition to car sensor system, the millimeter wave radar has started to find use in applications ranging from helicopter obstacle detection to health care and from intrusion detection to airport body scanners.

In this work, we will present the millimeter wave radar technology behind a novel assistive device for the orientation and mobility of the visually impaired. The solution is based on 24 GHz frequency-modulated continuous wave (FMCW) radar.

RADAR SYSTEM

The millimeter wave radar system used as the core of the assistive device and the top level schematic is shown in Fig. 1 and person wearing the prototype version of the assistive device is shown in Fig 2.

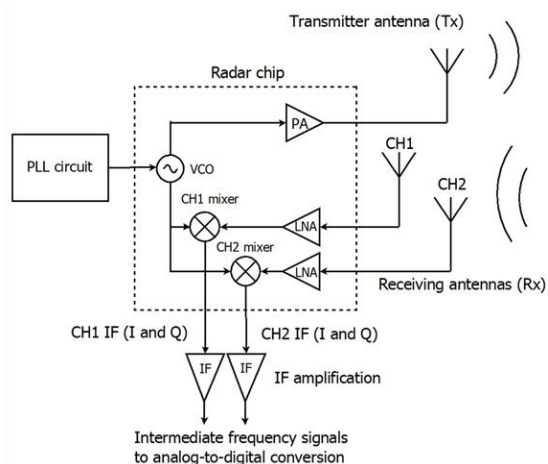
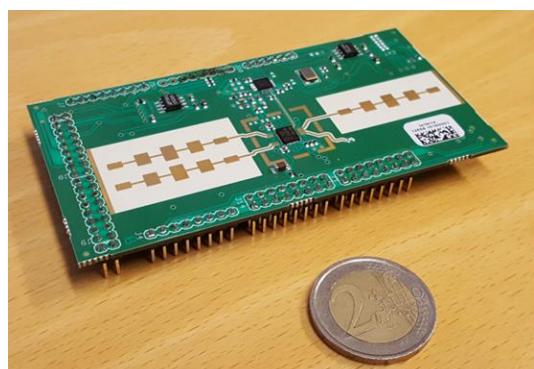

Figure 1. On the left hand side a photograph of the millimeter wave printed circuit board with antenna array and on the right hand side is the top level schematic of the radar systems analog (millimeter wave and IF frequency) parts.



Figure 2. Person wearing the prototype version of the assistive device.